

## Description

The high expansion foam generator HG-15 is primarily designed as an integrated part of the SKUM HOT-FOAM system, where air from the protected volume is used for the foam production, also under the presence of smoke and combustion gases.

## HG-15 advantages

- Low weight = easy to install
- No moving parts = minimized maintenance
- Stainless steel housing and net
- Modular system concept giving flexibility at installation
- High capacity, up to 18 m<sup>3</sup> foam/min

**Dimensions**

**HG-15**

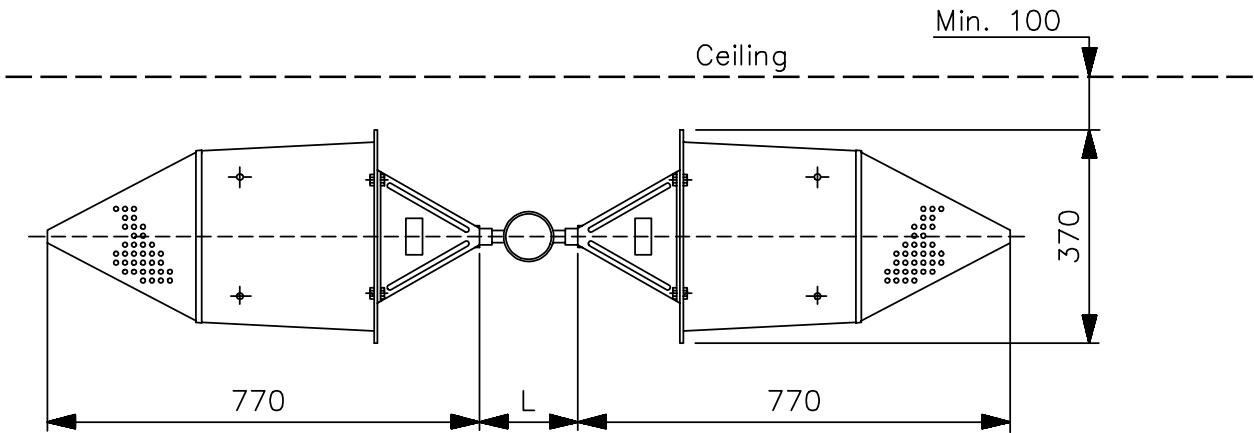

L=Min. 800 or mounted crosswise

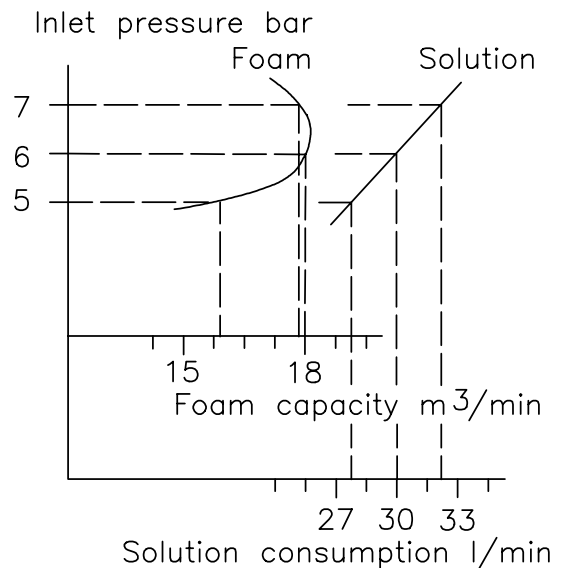
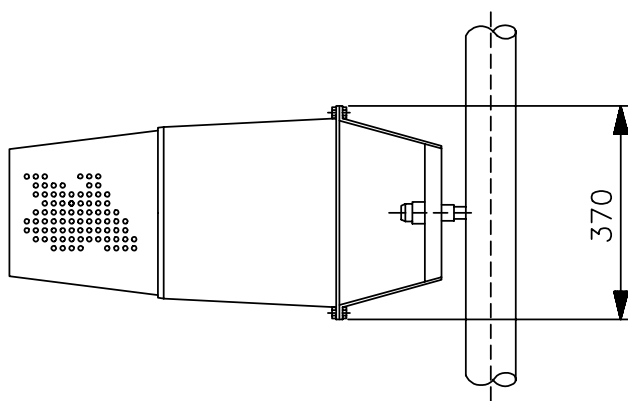

**Performance data**

1 bar = 0,1 MPa = 14,5 psi

Nominal rating: At inlet pressure 6 bar the solution consumption is 30 l/min. and the foam capacity is 18 m<sup>3</sup> /min.

Connection: Female 1/2" BSP  
 Material: Stainless steel  
 Weight: 5 kg/11 lbs



Technical changes reserved without notice