

Description

The basic function of this portable inline inductor is to inject foam concentrate into a water line. It provides a simple and dependable means of injection. The MI inductor is designed to handle high counter pressures, related to the inlet pressure, meaning that a long distance between

inductor and the foam generator can normally be tolerated.

Each inline inductor is calibrated for a given fixed flow/pressure relation. It can be connected anywhere in the main water line between the pressure water source and the foam generato(s).

Dimensions

MI-25 P

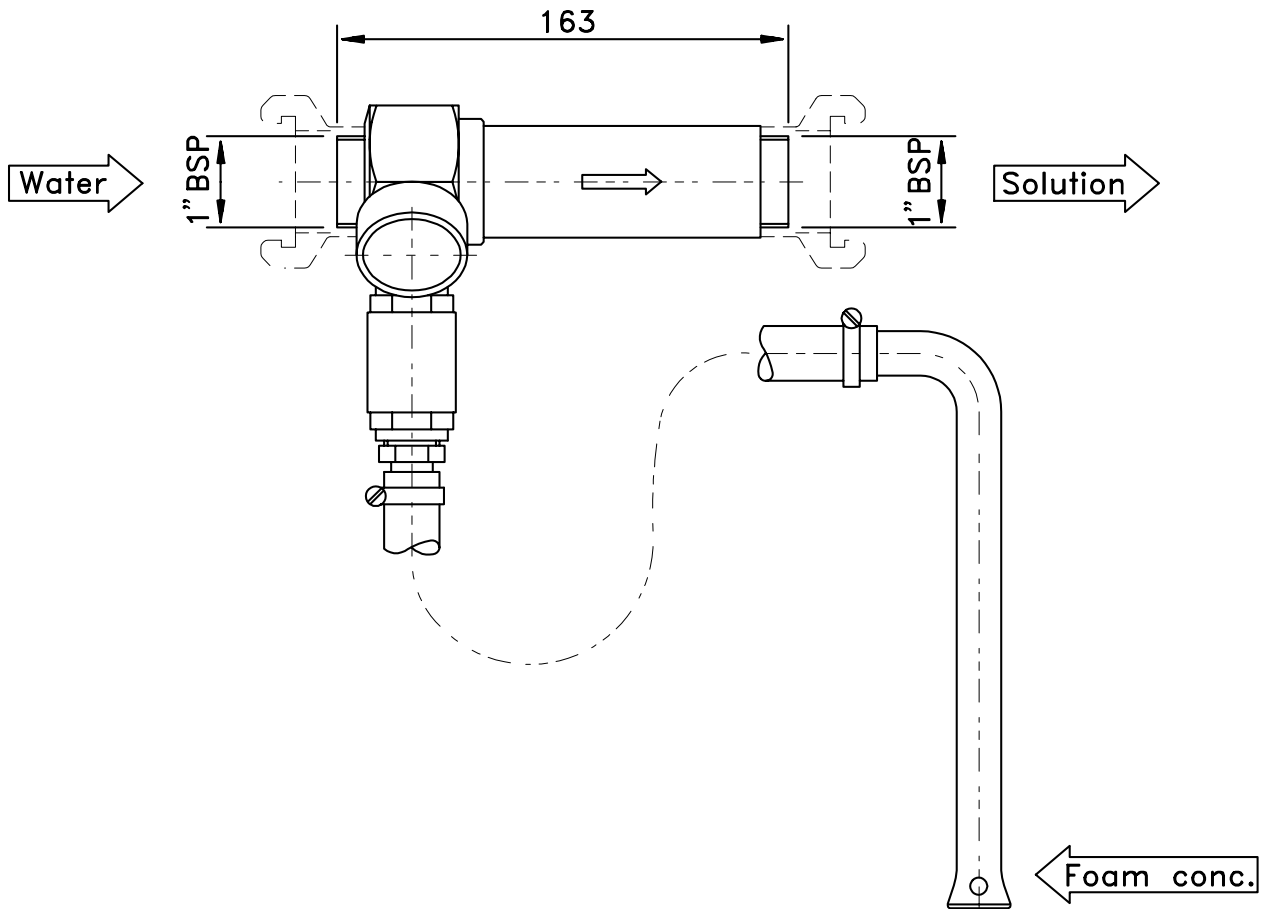

Performance data

1 bar = 0,1 MPa = 14,5 psi

Working pressure:	Max 16 bar/232 psi
Water capacity at 16 bar:	Max 400 l/min - 105 USGPM
Proportioning:	Max 6%
Pressure drop:	Approx. 35% of inlet pressure
Material:	Brass
Connection:	Male 1" BSP or specified coupling
Weight:	2,6 kg/5,7 lbs

Foam concentrate hose 1/2" L=1,5 m, pick-up tube, pressure gauge and check valve included.



Technical changes reserved without notice