

Horn antenna gauge RTG 3920

The horn antenna gauge RTG 3920 is designed for easy mounting in small size openings on storage tanks with fixed roofs.

The RTG 3920 gauge gives superior reliability and has no moving parts and no contact with the liquid. It transmits radar waves from a horn antenna towards the liquid surface in the tank.

As all TankRadar Rex gauges, RTG 3920 is temperature controlled and has a digital reference for highest level accuracy.



RTG 3920 can be installed on the existing nozzle and measure with full accuracy.

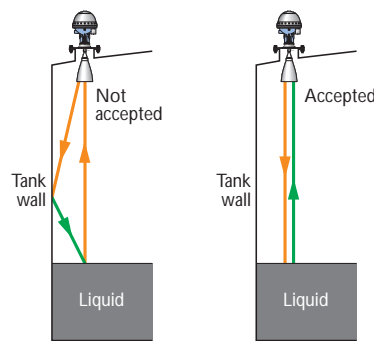

The RTG 3920 radar signal has circular polarization, reducing the influence from tank wall echoes.

The RTG 3920 gauge is designed for general use on oil products and chemicals. (Except for asphalt and similar products giving thick antenna deposits where the parabolic antenna gauge RTG 3930 is recommended.)

High versatility

RTG 3920 has inputs for temperature sensors, HART® based pressure sensors, other analog inputs as well as analog and relay outputs. All data are transmitted on the two-wire TRL/2 field bus. Temperature sensors are connected directly to the gauge or via a separate Data Acquisition Unit.

The gauge can be equipped with other output buses such as Profibus DP or Tiway and also emulate other vendor's buses.

Installation with tank in service

The gauge is mounted without taking the tank out of operation. Normally existing field cabling is used for the transmission of field data.

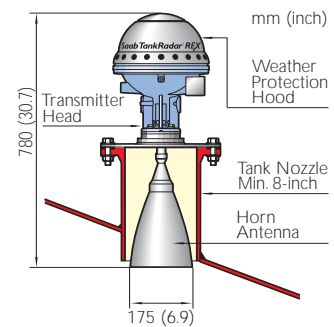

Features

- High reliability.
- Custody transfer accuracy.
- Easy installation on 8-inch nozzles.
- Drip-off antenna according to API Chapter 3.1 B.
- Emulates other vendor's field buses.
- TÜV approved for overfill protection.
- Integrated in TankRadar Rex inventory tank gauging system.

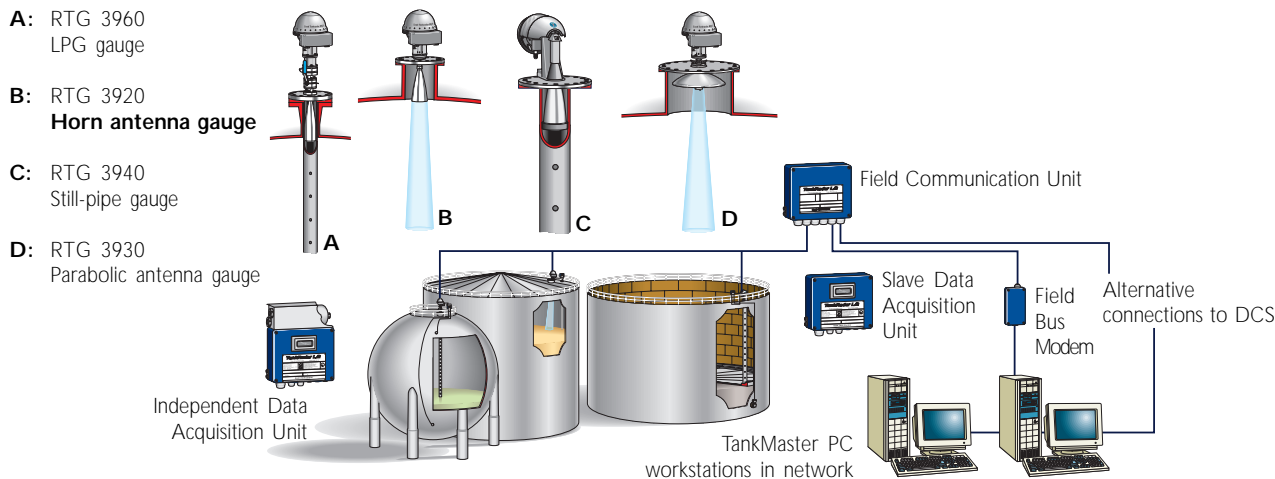

An overview of the RTG 3920 gauge integrated in the TankRadar Rex system.

Specification RTG 3920	
Measuring principle	FMCW radar with digital reference and temperature control
Antenna type	High precision curvature horn with drip-off sealing, [175 mm (7 in.) diameter]
Instrument accuracy	± 0.5 mm ($\pm 5/256$ in.) [2σ value]. Maximum deviation: ± 0.8 mm (1/32 in.)
Measuring range	0.8 to 20 m (2.6 to 65 ft) below flange [0.3 to 30 m (1 to 100 ft) below flange with reduced accuracy]
Temperature	Ambient: -40° C to 70° C (-40° F to 158° F), Product: max 230° C (450° F)
Pressure	-0.2 to 2 bar (-2.9 to 30 psig)
Material exposed to tank atmosphere	Acid proof steel EN 1.4436 (AISI 316), PTFE (Teflon [®]) and FPM (Viton [®])
Supply voltage	100-240 VAC, 50-60 Hz , optional 34-70 VAC or 48-100 VDC
Outputs /inputs	Outputs: TRL/2 field bus, 1 pc 4-20 mA, HART [®] , Profibus DP, Tiway, 2 pcs relays, other vendor's field buses Inputs: Temp (Pt 100), 2 pcs 4-20 mA (of which one HART [®] , Master)
Display	On separate DAU, RDU or remotely in control room
Tank opening	Nozzle diameter: minimum 200 mm (8-in.) Mounting flange: 8-in. ANSI B 16.5 150 lbs/DN 200 PN 10 DIN 2632/SS2032
Housing	Aluminium, designed for IP 66 & 67
Weight	20 kg (44 lbs)
Hazardous locations certifications	EEx d[ia] IIB T6 (EN50014, EN50018 and EN50020 Europe) Class 1, Div I, Groups C and D (UL1203, UL913 USA)

Quality and environmental system certified by DNV - ISO 9001 - ISO 14001

Your local representative:

HEADQUARTERS:

Saab Rosemount Tank Control
 Box 130 45
 SE-402 51 Göteborg, SWEDEN
 Tel: int. +46 31 337 00 00
 Fax: int. +46 31 25 30 22
 E-mail: sales.stc@marine.saab.se
 Website: www.saab.tankradar.com
 Find your local representative on our website

